

ORIGINI

THE NEW
SHAPE
OF COLOUR

GINI

LA NUOVA
FORMA DEL
COLORE

GESSI THE
PRIVATE
WELLNESS
COMPANY®



ORIGINI
THE NEW SHAPE OF COLOUR

INDEX

13 **Warm**

Cipria
Warm Bronze PVD
Dark Bronze

29 **Neutral**

Greige
Finox
Nickel PVD

45 **Accent**

Ocra
Brass Brushed PVD
Matt Black

61 **Materic**

Coral
Copper Brushed PVD
Black Metal PVD

ARMONIE
METACROMATICHE

METACHROMATIC
HARMONY

AN ENCOUNTER BETWEEN
COLOUR, MATERIAL AND FINISH
*GESI transforms characters into colours and
presents five triads associating them with as
many personalities.*

INCONTRO TRA COLORI,
MATERIALI E FINITURE
*GESI traduce i caratteri in colori e
presenta cinque triadi associandole ad
altrettante personalità.*

77 **Nature**

Agave
Black Metal Brushed PVD
Chrome

93 **Product
list**



TO THE ORIGINS of well-being, emotion and beauty

Origini is born from the aspiration to seek form in their purest and most original dimension to express a new way of conceiving well-being. The flowing of water in its most natural representation connects us with our inner, instinctive part. A soft and fluid sign, without solution of continuity, characterises iconic and solid forms. The symbolic reference to the formal archetype generates creations that express beauty and emotion. Design, combined with material and colour, satisfies an emotional need. The new spa-

ces are designed according to immaterial values such as air and water quality, silence, privacy and are finally tailored to emotions. Colour is the emblem of this transition, from the material to the immaterial, from the objective to the subjective sphere. With the Origini collection, Gessi explores the new emotional dimension of colour that places the person at the centre, and proposes decorative elements that combined together allow you to create, in absolute freedom, scenarios where you can finally feel like the protagonist of your own space.

ALLE ORIGINI DEL BENESSERE, EMOZIONE E BELLEZZA

Origini nasce dalla ricerca delle forme nella loro dimensione più pura e originaria per esprimere un nuovo modo di concepire il benessere. Il fluire dell'acqua nella sua rappresentazione più naturale ci connette con la nostra parte interiore e istintiva. Un segno morbido e fluido, senza soluzione di continuità, caratterizza forme iconiche e solide. Il richiamo simbolico all'archetipo formale genera creazioni che esprimono bellezza ed emozione. Il design, unito alla materia e al colore, soddisfa un bisogno emotivo. I nuovi spazi vengono progettati in base a valori immaterici come la qualità dell'aria e dell'acqua, il silenzio, la privacy e sono finalmente a misura delle emozioni. Il colore è l'emblema di questo passaggio, dal materiale all'immateriale, dalla

sfera oggettiva a quella soggettiva. Gessi con la collezione Origini esplora la nuova dimensione emozionale del colore che pone al centro la persona. E propone elementi di arredo che combinati tra loro consentono di creare in assoluta libertà scenari dove sentirsi finalmente protagonisti del proprio spazio.

“Colour is an emotional need”

*“IL COLORE È UN NOSTRO
BISOGNO EMOTIVO”*

Francesca Valan

— A rediscovery of archetypal forms and iconic materials

Return to the origins, to the archetypal forms and materials of the past with this innovative collection designed by Gessi for a new level of contemporary well-being. From the harmonious union of shape and colour, materials and finishes, ORIGINI emerges. Function drives form and metal defines it, but it is the blend of carefully combined coloured pigments, metals and finishes that give rise to the five triads that are the inspiring selection for the most original bathroom furniture. The skilful metalwork is strung together in a circle that is repeated in modular ratios. Aesthetic and emotional delight springs forth from the sight and the feel of timeless shapes that are inspired by the sources of long ago. Reinterpreted in an iconic manner, they create solid forms and infinite variations with a play on matching and contrast. ORIGINI is the initiation of the new which, by revealing history and location, projects itself into the future and assembles its yesterdays and its tomorrows, piece by piece. In a new form of colour.

LA RISCOPERTA DELLE FORME ARCHETIPE E DEI MATERIALI ICONICI

Ritornare alle origini, alle forme archetipe e ai materiali di un tempo con una innovativa collezione pensata da Gessi per il benessere contemporaneo. Dall'unione armonica di forma e colore, materiali e finiture, nasce ORIGINI. La funzione guida la forma e il metallo la definisce, ma è il mix di pigmenti colorati, metalli e finiture, accuratamente combinati tra loro, a dare vita a cinque triadi che ispirano nella scelta del più originale arredo bagno. Le sapienti lavorazioni dei metalli sono raccordate in un cerchio che si ripete in proporzioni modulari. Il piacere estetico e emozionale scaturisce dalla vista e dal tatto di forme senza tempo che si ispirano alle fonti di una volta. Reinterpretate in chiave iconica creano solide forme e infinite personalizzazioni con giochi di abbinamenti e di contrasti. ORIGINI è l'inizio del nuovo che, svelando la storia e i luoghi, si proietta nel futuro e assembla, pezzo dopo pezzo, il bagno, il suo ieri e il suo domani. Nella nuova forma del colore.

THE NEW shape of colour

LA NUOVA FORMA DEL COLORE

LA LIBERTA' PERSONALE DI CREARE L'AMBIENTE A PROPRIA IMMAGINE

ORIGINI lascia spazio alla libertà individuale di interpretare gli ambienti secondo la propria personalità. Il colore si allinea a forme senza tempo e trasforma il luogo più intimo dell'abitare in uno spazio emozionale, che va oltre la stanza da bagno. Offre una varietà di colori e finiture accuratamente selezionati per mantenere l'armonia con le dominanti cromatiche dei diversi contesti. Dalle tonalità calde e naturali a quelle più neutre e tecniche, in continuità con i percorsi visivi della casa, consente di personalizzare i diversi elementi senza seguire le mode. Cinque triadi di colori iconici che si abbinano ad altrettanti ritratti cromatici per evidenziare un'attitudine della personalità. Si possono scegliere i colori della natura che rispecchiano un'identità per creare spazi fluidi da vivere in libertà e con gioia: rosa Cipria tattile monocromatico, argilla Greige acromatico neutrale, Ocra metacromatico anticonformista, cotto Coral polimaterico tradizionale e verde Agave metamaterico naturale.

ORIGINI leaves room for personal freedom to create environments that reflect one's own personality. Colour aligns with timeless shapes and transforms the most intimate living area into an emotional space that extends beyond the bathroom. It provides a variety of colours and finishes that are carefully selected to be harmonious with the dominant colours in differing contexts. From warm, natural tones to more neutral, technical ones, in continuity with the visual pathways of the home, it allows for personalisation of the many diverse items and avoiding trends. Five triads of iconic colours are combined with five colour portraits to highlight a predisposition for personality. The colours of nature that reflect an identity may be selected to create fluid spaces to be experienced in freedom and joy - monochromatic tactile Cipria, neutral achromatic Greige clay, non-conformist metachromatic Ochre, traditional multi-material Coral cotto and natural metamaterial Agave green.

Personal freedom to create the environment in one's own image —



BEYOND SHAPE

OLTRE LA
FORMA



CHR OMA TIC

RITRATTI
CROMATICI

POR TRA ITS

When there is correspondence between visual and tactile perception, we are looking at metachromatic harmony, a balanced relationship between colour, material and finish. ORIGINI is the elegance of metachromatic harmony where iconic forms are coupled with finishes such as brass, copper, steel as well as colours belonging to our visual landscape such as cotto, ochre, clay, pink and green. The collection provides the freedom not only to select a material triad, but also to interweave components within it. With the five triads, experimentation with new chromatic patterns is possible that goes beyond classic harmony, because they establish a dialogue between the identity of a location and the personality of its inhabitants, between the past and the future, between interior and exterior spaces. To complete the effect, four round decorative elements can be freely positioned onto the various components - plain, polished metal or milleluci in a variety of finishes and in the ART version, with geometric designs that capture the rounded shapes in the collection.

**Metachromatic
harmony and
the personality
of its
inhabitants —**

LE ARMONIE METACROMATICHE E LA PERSONALITÀ DI CHI LE ABITA

Quando c'è una corrispondenza tra la percezione visiva e quella tattile siamo di fronte a un'armonia metacromatica ovvero la relazione di equilibrio che si crea tra colori, materiali e finiture. ORIGINI è l'eleganza delle armonie metacromatiche dove alle forme iconiche vengono associate finiture come l'ottone, il rame, l'acciaio e colori appartenenti al nostro paesaggio visivo come il cotto, l'ocra, l'argilla, il rosa e il verde. La collezione offre la libertà non solo di scegliere una triade materica, ma all'interno di essa di mescolare tra loro gli elementi. Con le cinque triadi si possono sperimentare nuovi schemi cromatici che vanno oltre le armonie tradizionali, perché fanno dialogare l'identità di un luogo con la personalità di chi ci abita, il passato con il futuro, gli spazi interni con quelli esterni. Per completare il gioco, possono essere posizionati liberamente sui diversi elementi quattro inserti: tinta unita, in metallo lucido o milleluci nelle varie finiture e nella versione ART, con grafiche geometriche che riprendono le forme arrotondate della collezione.



ORIGINI WARM

FOR PEOPLE WHO LOVE INTIMACY,
WHO ARE ROMANTIC AND KIND

*Per persone che amano l'intimità,
romantiche e gentili*

CIPRIA
DARK
BRONZE
WARM
BRONZE
ZE

For people who love intimacy, who are romantic and kind. WARM is a monochromatic triad with a dominant warm overtone, comprising Matt Cipria, Warm Bronze and Dark Bronze finishes. Designed for those who wish to regenerate by carving out a private space in a bathroom, perhaps with a bathtub, where visual contrast is diminished to enhance tactile and olfactory perception. This is a cosy, relaxing environment, where the softness of pink is an invitation to leave the world at the doorstep. A chromatic portrait of one who wishes to lose track of time.

Per persone che amano l'intimità, romantiche e gentili. WARM è una triade monocromatica con dominante calda, che comprende le finiture Cipria super opaco, Warm Bronze e Dark Bronze. Pensata per chi si rigenera ritagliandosi uno spazio privato in una stanza da bagno, possibilmente con vasca, dove si abbassano i contrasti visivi per esaltare le percezioni tattili e olfattive. È un ambiente avvolgente e rilassante, dove la morbidezza del rosa invita a lasciare fuori il mondo. È il ritratto cromatico di chi vuole perdere la cognizione del tempo.



TACTILITY

Metachromatic harmony is an undisputed innovation in the world of wellness. For the first time, colour and finish combinations are possible within the same room. Super matt Cipria Warm Bronze and Dark Bronze constitute the low chromatic contrast WARM triad. The same finishes for the mixers are also available for the round inserts, which can be freely matched to personalise all components.

Le armonie metacromatiche sono un'innovazione assoluta nel mondo wellness. Per la prima volta si possono mescolare tra loro i colori e le finiture all'interno della stessa stanza. Cipria super opaco, Warm Bronze e Dark Bronze compongono la triade WARM, a basso contrasto cromatico. Le stesse finiture dei miscelatori sono proposte anche per gli inserti tondi che possono essere liberamente accostati per personalizzare tutti gli elementi.

CIPRIA FOR A NEW TACTILE AND REFINED PORTRAYAL

Cipria per una nuova interpretazione tattile e raffinata

From the abstract form of the original cast iron fountains, the washbasin mixer takes up the proportions and endows them with a contemporary twist. Cipria accentuates the softness of the lines and, as a round detail, creates unusual contrasts.

Dall'astrazione delle forme originali delle fontane in ghisa, il miscelatore ne riprende le proporzioni dandone un'interpretazione attuale. Il Cipria ne accentua la morbidezza delle linee e come dettaglio tondo crea contrasti inediti.



66002#845 + 66600#275
Basin Mixer, without waste + finish insert/
Miscelatore Lavabo, senza scarico + inserto in finitura



ROUND DECORATIVE ELEMENTS AS A MARK OF UNIVERSAL EXPRESSION

Il tondo come segno espressivo universale



The round decorative element is interchangeable on the different components and is also available in the ART version, where delicate, elegant compact Cipria tones accentuate the curves. The graphic decoration binds together the polished/matt effects and the darker highlights of the warmer triad.

Intercambiabile sui vari elementi, l'inserto è proposto anche nella versione ART dove i toni delicati ed eleganti del Cipria assecondano le curve. Il decoro grafico lega fra loro gli effetti lucido/opaco e i chiari scuri della triade più calda.

66002#275
66002#726
Basin Mixer, without waste /
Miscelatore Lavabo, senza scarico
66602#275
ART Insert / Inserto ART



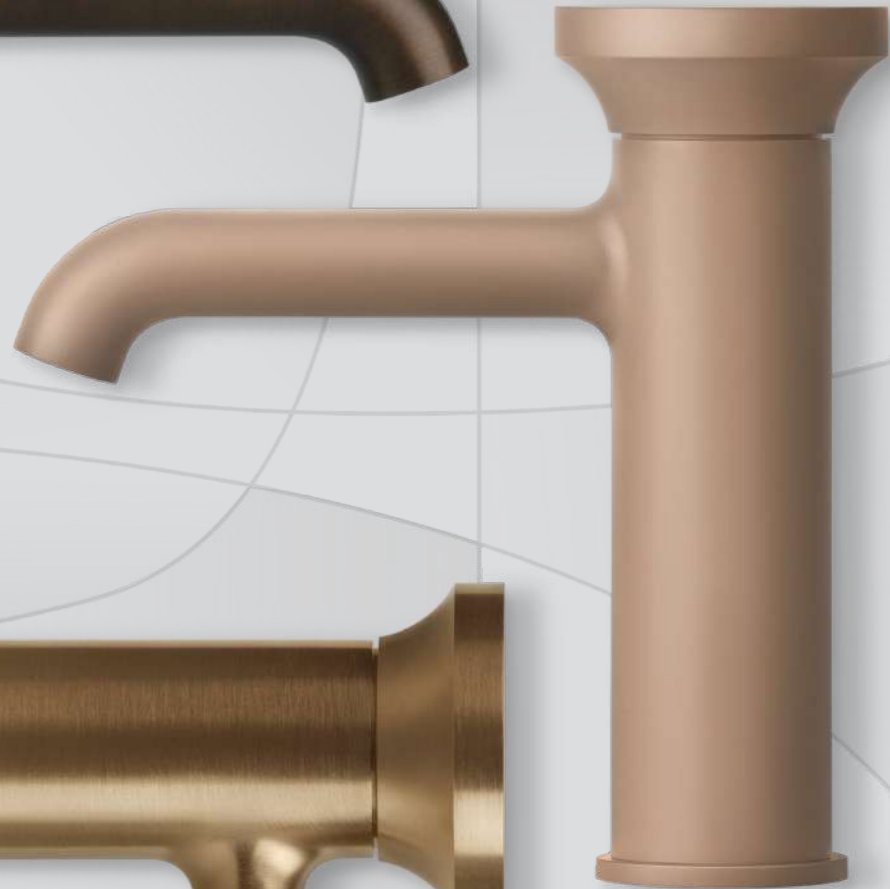





WARM, EMBRACING TONES THAT IGNITE THE SENSES

*Tonalità calde e avvolgenti che
accendono i sensi*

To lose track of time, those with a romantic bent will find refuge in a privacy space that allows one to indulge a sensual atmosphere, where fragrances, sounds and materials enhance perception.

Per perdere la cognizione del tempo, chi ha un'attitudine romantica trova rifugio in uno spazio dedicato alla privacy che consente di abbandonarsi ad un'atmosfera sensuale, dove profumi, suoni e materiali esaltano ogni percezione.

66002#726

66002#275 + 66600#726

66002#726 + 66602#275

Basin Mixer, without waste + finish insert /

Miscelatore Lavabo, senza scarico + inserto in finitura





LARGE VOLUMES INTERACT WITH SLENDER TUBING

*Volumi importanti interagiscono
con tubolari sottili*

The modular nature of the components in the ORIGINI collection, where round motifs are repeated to create a clean, flawless aesthetic effect, can also be enjoyed in the showerhead, which is balanced by the formal lightness of the sliding rail set and tubular accessories.



La modularità degli elementi della collezione ORIGINI, dove il segno rotondo si ripete creando giochi estetici puliti e perfetti, si ritrova nel soffione calibrato dalla leggerezza formale dell'asta saliscendi e dei tubolari degli accessori.

66150#726

Wall-mounted adjustable showerhead /
Soffione a parete orientabile

66142#726 + 66600#275

Sliding rail with hose and water outlet + finish insert /
Asta saliscendi con presa acqua + inserto in finitura

54073_66079#845 + 66602#275

Wall-mounted shower mixer, two-way + ART insert /
Miscelatore doccia a parete, due vie + inserto ART

INDULGE IN MOMENTS OF HEADY BLISS AND LINGER OVER ELEGANT DETAILS

Concedersi momenti inebrianti indulgiando su dettagli eleganti



The circle, shape par excellence which transcends style and fashion, and finds expression in all the items in the collection. It is, however, the skilfully crafted metals that enhance the free gesture of creating a space where you can feel completely at ease.

Il cerchio, forma perfetta per eccellenza che trascende stili e mode, trova espressione in tutti gli elementi della collezione. Ma sono i metalli sapientemente lavorati ad esaltare il gesto libero di creazione di uno spazio in cui sentirsi completamente a proprio agio.



726
WARM BRONZE BRUSHED PVD

845
DARK BRONZE

275
CIPRIA

CIPRIA

NCS S3010-Y50R

LAB 65,23/7,86/13,70

LCH 65,23/15,79/60,14

RGB 182/153/134

CMYK 0/16/26/29

66502#845 45cm
66500#845 30cm
Towel-rail / Porta Salvietta

66521#845 + 66600#275
Wall-mounter robe hook + finish insert /
Appendino a parete + inserto in finitura

46189_66028#726 + 66600#275
Freestanding bath mixer + finish insert /
Miscelatore vasca da terra + inserto in finitura

WARM

Within the triad, endless possibilities exist for the arrangement of bathroom furniture that best reflects one's personality. The choice ranges from matching shades to the milleluci decorative element on the Warm Bronze mixer.

All'interno della triade sono infinite le possibilità di comporre l'arredo bagno che rispecchi al meglio la propria personalità. La scelta va dal ton sur ton all'accostamento del tondo milleluci sul miscelatore Warm Bronze.

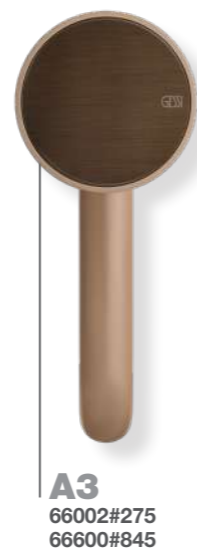
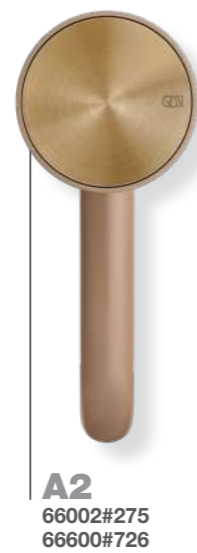
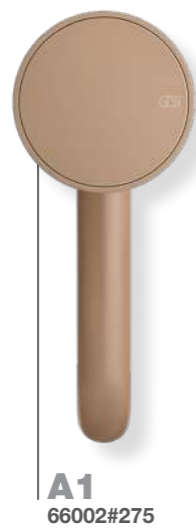
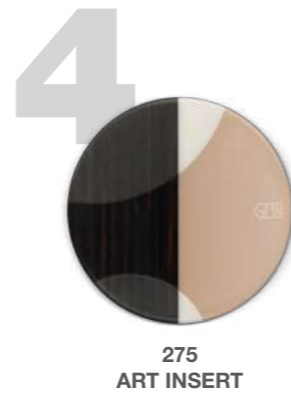

B

726

WARM
BRONZE PVD

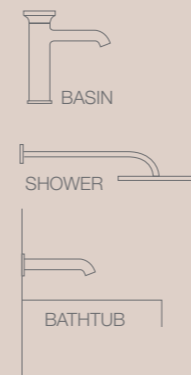

C

845

DARK BRONZE

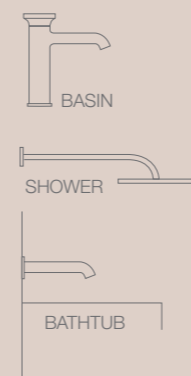
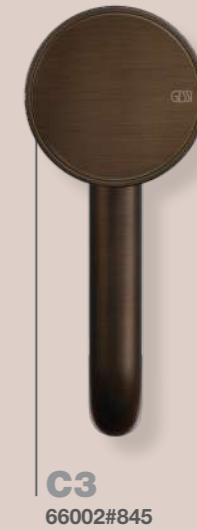

ORIGINI NEUTRAL

FOR CITY DWELLERS AT ALL LATITUDES, FOR
THOSE WHO ARE ALWAYS ON THE MOVE

*Per chi vive in città a tutte le latitudini,
per chi è sempre in movimento*

For city dwellers at all latitudes, for those who are always on the move. Metallic and achromatic triad featuring a blend of Matt Greige, Brushed Finox and polished Nickel finishes. It is neutral, contemporary and highly customised.

Suitable for those with an uncluttered personality as well as for the multifaceted alike. It leaves space for those who love music or fragrance, for those who seek merriment in colourful accessories but, at the same time, provides a neutral space for those who like peace and quiet. It is a chromatic portrait of those who are always on the move.

Per chi vive in città a tutte le latitudini, per chi è sempre in viaggio. Triade metallica e acromatica caratterizzata dal mix di finiture Greige opaco, Finox Brushed Nickel spazzolato e Nickel lucido.

È neutra, contemporanea e ad alta personalizzazione. Adatta sia a chi ha una personalità essenziale sia a chi, al contrario, è poliedrico. Lascia spazio a chi ama la musica o i profumi, a chi cerca l'allegria negli accessori colorati ma al tempo stesso garantisce uno spazio neutro a chi ama il silenzio. È il ritratto cromatico di chi non si ferma mai.

GRE
IGE
FI
NOX
NICK
EL



CUSTOMISATION

The opacity of the Greige balances the lustre of the mirrored surfaces. With no chromatic contrast in the NEUTRAL triad, neutral colours assist in the interpretation of forms, while the finishes join with each other and with their surroundings in an interplay of highlights. Matt Greige, Brushed Finox Nickel and Polished Nickel may be blended to accentuate the three-dimensionality in functional, minimalist metachromatic harmony.

L'opacità del Greige bilancia la lucentezza delle superfici specchiate. Senza contrasto cromatico nella triade NEUTRAL i colori neutri aiutano nella lettura delle forme, mentre le finiture legano tra di loro e con l'ambiente circostante in un gioco di riflessi. Greige opaco, Finox Brushed Nickel e Nickel lucido possono essere mescolati per accentuare la tridimensionalità di un'armonia metacromatica funzionale ed essenziale.

THE PORTRAYAL OF ONE'S OWN PERSONALITY

L'interpretazione della propria personalità

Choice as the highest form of self-expression. High or medium, the mixer is the original component at the heart of the many variations that can be afforded to a neutral, understated environment.

La scelta come massima forma di espressione del sé. Alto o medio, l'erogatore è l'elemento originale alla base delle molteplici interpretazioni che si possono dare di un ambiente neutro ed essenziale.



66004#149

Tall version Basin Mixer, without waste /
Miscelatore Lavabo alto, senza scarico

66006#273

Medium version Basin Mixer, without waste /
Miscelatore Lavabo medio, senza scarico

66004#149 + 66602#273

Tall version Basin Mixer, without waste + ART insert /
Miscelatore Lavabo alto, senza scarico + inserto ART



AN ACCENT IN A THIN METAL FRAME

Un accento in cornice metallica sottile

The decorative element, which stems from mechanically processed metal bases, further customises the room. It fits into a wafer-thin metal frame and, in the NEUTRAL triad, is enhanced when in milleluci Finox Brushed Nickel combined with a Matt Greige mixer.

L'inserto, che nasce da basi metalliche dalle lavorazioni meccaniche, personalizza ulteriormente l'ambiente. Si inserisce in una cornice metallica sottilissima e nella triade NEUTRAL si esalta se in Finox Brushed Nickel milleluci abbinato a un miscelatore Greige opaco.







NEUTRAL HARMONY THAT LEAVES SPACE FOR THE IMAGINATION

*Un'armonia neutra che lascia
spazio all'immaginazione*

This is a continuously evolving environment where one can express oneself in complete freedom. Physical elements such as colourful, intangible accessories – fragrances and background music – may also be accommodated. Silent matt, brushed or mirrored surfaces create an interplay of highlights that replace colour vibrations.

È un ambiente in continua evoluzione dove esprimersi in libertà. Possono essere inseriti elementi fisici come accessori anche molto colorati e immaterici come fragranze e sottofondi musicali. Le superfici silenti opache, spazzolate e specchianti creano giochi di riflessi che sostituiscono le vibrazioni del colore.



66004#149 + 66602#273

Tall version Basin Mixer, without waste + ART insert /
Miscelatore Lavabo alto, senza scarico + inserto ART



66004#149 + 66600#720

Tall version Basin Mixer, without waste /
Miscelatore Lavabo alto, senza scarico



66004#273

Medium version Basin Mixer, without waste /
Miscelatore Lavabo medio, senza scarico

66601#506

Cristalplant® counter washbasins, without overflow waste /
Lavabo da appoggio in Cristalplant®, senza scarico troppopieno





FOR REVITALISING BODY CARE

Per una rigenerante cura del corpo

The ceiling-mounted, rain-effect shower head and the waterfall gushing from the slit in the wall-mounted round decorative elements enhance each daily showering experience. In the interconnected nature of things, ORIGINI rediscovers the finest expressions of Gessi Private Wellness.

Sublimano il gesto quotidiano della doccia il soffione a soffitto effetto pioggia e la cascata d'acqua che sgorga di taglio dal tondo a parete. Nella circolarità, ORIGINI ritrova le migliori interpretazioni del benessere privato firmato Gessi.

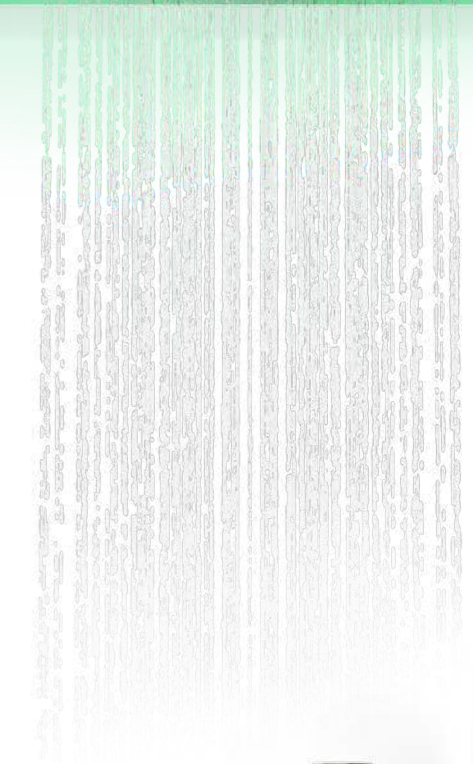
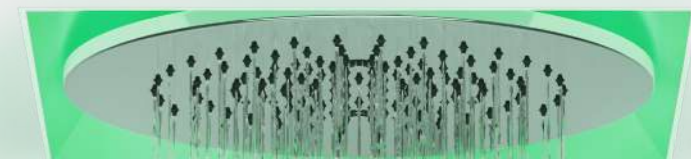
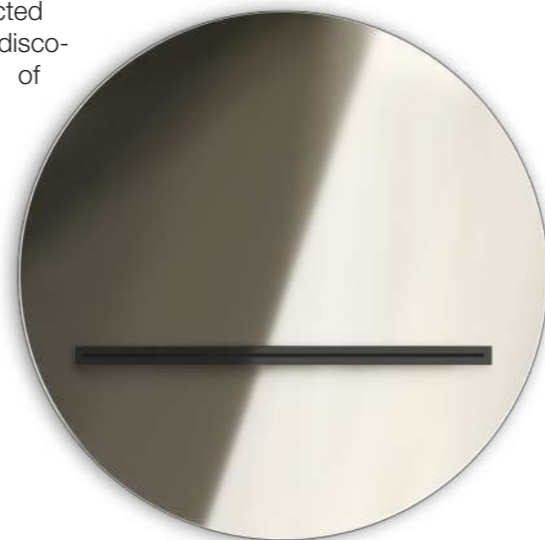

57601 57018#720

Shower System Ø350 mm - RAINFALL function
Sistema Doccia Ø350 mm, funzione PIOGGIA

65295#720

Waterfall shower spout / Bocca doccia a cascata

63013 66224#149 + 66600#273

Thermostatic mixer for three simultaneous functions, with push-button on/off controls + finish insert / Miscelatore termostatico a tre funzioni simultanee, con pulsanti on/off + inserto in finitura

66123#149 + 66600#273

Shower set + finish insert / Set doccia + inserto in finitura

ARCHITECTURAL INTERPLAY IN THE PORTRAYAL OF DETAIL

*Giochi architettonici nell'interpretazione
dei dettagli*



With its clean, minimalist design, the accessories are embellished in their surfaces, revealing an eye for detail which is the hallmark of Italian design excellence.

Dal design minimale e pulito, gli accessori risultano preziosi nelle superfici che rivelano un'attenzione ai dettagli, segno distintivo dell'eccellenza italiana.

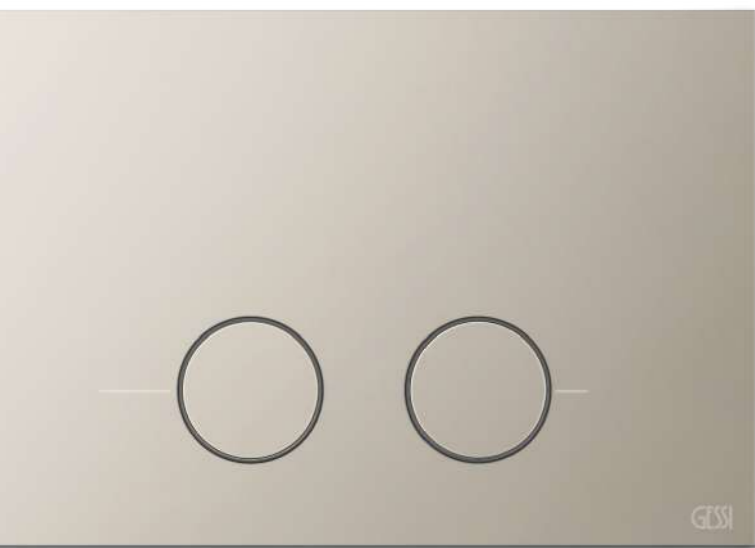

149
FINOX

720
NICKEL PVD

273
GREIGE

GREIGE

NCS 2502Y

LAB 69,69/0,95/9,01

LCH 69,69/9,06/83,99

RGB 179/169/154

CMYK 0/6/14/30

66419#149

White wall-mounted brush holder /
Porta scopino a parete bianco

66455#149

Paper-roll holder / Porta rotolo

54611#720

Cover plate / Placca di finitura

66007273 + 66600#149

Bidet mixer + finish insert /
Miscelatore Bidet + inserto in finitura

NEUTRAL

Several combinations are possible when the base is neutral, from the low-contrast combination of Matt Greige, with the insert of the same colour, to the more contrasting combination of a mirrored surface and elements with a brushed finish.

Sono diversi gli abbinamenti possibili quando la base è neutra, da quello a basso contrasto del Greige opaco con l'inserto nel medesimo colore a quello più contrastato tra superficie specchiante e elementi dalle finiture spazzolate.

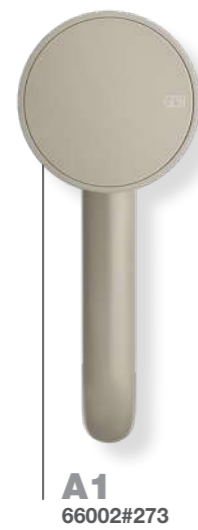
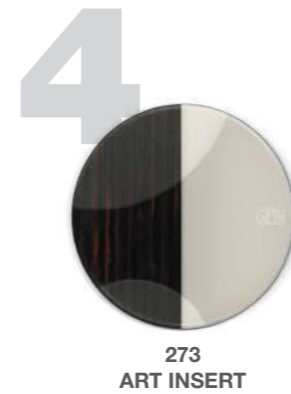

GREIGE



FINOX BRUSHED
NICKEL



NICKEL PVD



ORIGINI ACCENT

FOR COSMOPOLITAN, OUTGOING,
DARING INDIVIDUALS WHO APPRECIATE
THE VALUE OF CONTRAST.

*Per persone cosmopolite, estroverse,
che osano, a cui piacciono i contrasti.*

OC
RA
MA
TT
BRA
SS

For cosmopolitan, outgoing, daring individuals who appreciate the value of contrast. A triad where Glossy Ochre, Matt Black and Brushed Brass establish a metachromatic profile. Ideal for an energising shower or in bathrooms of second homes. Also suitable for rooms, ACCENT may even be placed in entrance halls where colours can be intensified. This is followed by a graphic layout that allows the space to be subdivided by forcefully distinguishing the different elements. This is a chromatic portrait of those who are happy and non-conformist.

Per persone cosmopolite, estroverse, che osano, a cui piacciono i contrasti. Triade dove l'Ocra lucido, il Nero opaco e l'Ottone spazzolato definiscono un profilo metacromatico. Perfetta per una doccia energizzante o nel bagno di una seconda casa. Adatta anche in un locale, ACCENT può stare persino nell'ingresso dove si possono amplificare i colori. Segue uno schema grafico che consente di suddividere lo spazio caratterizzando con forza i diversi elementi. È il ritratto cromatico di chi è felice e anticonformista.



ENERGISING

The high-contrast graphic sign emphasises a triad with strong lines. ACCENT is metachromatic, since the golden shades of yellow are present as colour in the ochre and as metal in the brass. Matt black is the counterpoint to polished ochre and brushed brass, breaking up patterns and spaces, not least visually. Alternating light and dark elements suggest clear visual partitions within rooms.

Il segno grafico proposto ad alto contrasto sottolinea una triade dalle linee decise. ACCENT è metacromatica, perché le tonalità dorate del giallo si ritrovano come colore nell'ocra e come metallo nell'ottone. Il nero opaco fa da contrappunto all'ocra lucido e all'ottone spazzolato rompendo gli schemi e gli spazi anche visivamente. L'alternarsi di elementi chiari e scuri suggerisce partizioni visive nette all'interno degli ambienti.

ORIGINAL SHAPES REVISITED IN AN ECLECTIC TWIST

Forme originarie rivisitate in chiave eclettica

Like the gushing water, it has a curved opening that evokes the shapes found in nature. An unusual, irregular shape, enhanced in all its beauty and eclecticism by the formal and graphic cleanliness of the controls.



Come uno zampillo d'acqua ha la bocca ricurva che richiama forme presenti in natura. Una forma inedita e irregolare, valorizzata in tutta la sua bellezza ed ecletticità dalla pulizia formale e grafica dei comandi.

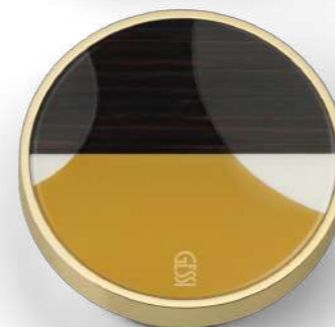

66014#727 + 66600#299 + 66602#277

Three-hole basin mixer, without waste + finish inserts / Gruppo lavabo 3 fori medio, senza scarico + inserti in finitura

66014#277

Three-hole basin mixer, without waste / Gruppo lavabo 3 fori medio, senza scarico

66025#299

Tall version basin spout / Bocca lavabo alto

66100#299 + 66600#277

Separate control + finish insert / Comando remoto + inserto in finitura



INVALUABLE ACCENTS WITH GOLDEN HIGHLIGHTS

Preziosi accenti dai riflessi dorati

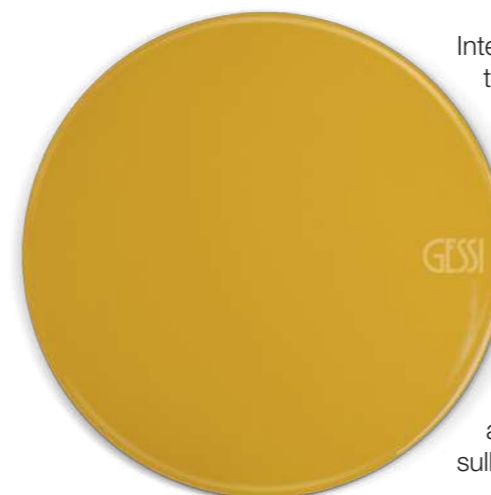

Interchangeable with each other as desired, the round decorative elements in the ACCENT collection meld into golden effects or stand out when contrasted. They become noticeable as accents when created in Matte Black on Brushed Brass.

Intercambiabili tra loro a piacere, gli inserti della collezione ACCENT si fondono in effetti dorati o risaltano se abbinati a contrasto. Diventano accenti evidenti se in metallo nero opaco sull'ottone spazzolato.







PUTTING THE WELL-BEING OF WATER BACK IN THE SPOTLIGHT

Per riportare al centro dell'attenzione il benessere dell'acqua

An expression of non-conformism, the ACCENT triad allows one to be daring when defining spaces, since it asserts water's leading role. It would be a pity to envisage it only in bathrooms, now that new lifestyles allow for greater freedom of expression.

Espressione di anticonformismo, la triade ACCENT permette di osare nella definizione degli spazi, perché rivendica il ruolo di protagonista dell'acqua. È un peccato immaginarla solo in bagno, oggi che i nuovi stili di vita consentono di esprimersi con maggiore libertà.



66014#277 + 66600#299 + 66602#277

Three-hole basin mixer, without waste + finish inserts
/ Gruppo lavabo 3 fori medio, senza scarico + inserti in finitura

66025#299

Tall version basin spout / Bocca lavabo alto

66100#299 + 66600#727

Separate control + finish insert /
Comando remoto + inserto in finitura

66601#509

Cristalplant® counter washbasins,
without overflow waste /
Lavabo da appoggio in Cristalplant®,
senza scarico troppopieno



THE CIRCLE AS A SYNTHESIS OF THE PURITY OF ARCHETYPAL FORMS

*Il cerchio come sintesi della purezza
delle forme archetipe*

Simple forms and large shower head volumes work together with slender tubular elements. The circle is repeated in a harmonious and regular manner throughout the collection and finds a solution to an interplay of contrasts in the wall-mounted controls.

Le forme semplici e i volumi importanti del soffione interagiscono con elementi tubolari sottili. Il cerchio si ripete in maniera armonica e regolare nella collezione e trova nei comandi a parete la soluzione al gioco dei contrasti.

63352#299

Ceiling-mounted adjustable showerhead /
Soffione a soffitto orientabile

54169_66134#299 + 66600#277

Thermostatic mixer, two-way + finish insert / Miscelatore termostatico doccia, 2 vie + inserto in finitura

66123#299 + 66600#277

Shower set + finish insert /
Set doccia + inserto in finitura

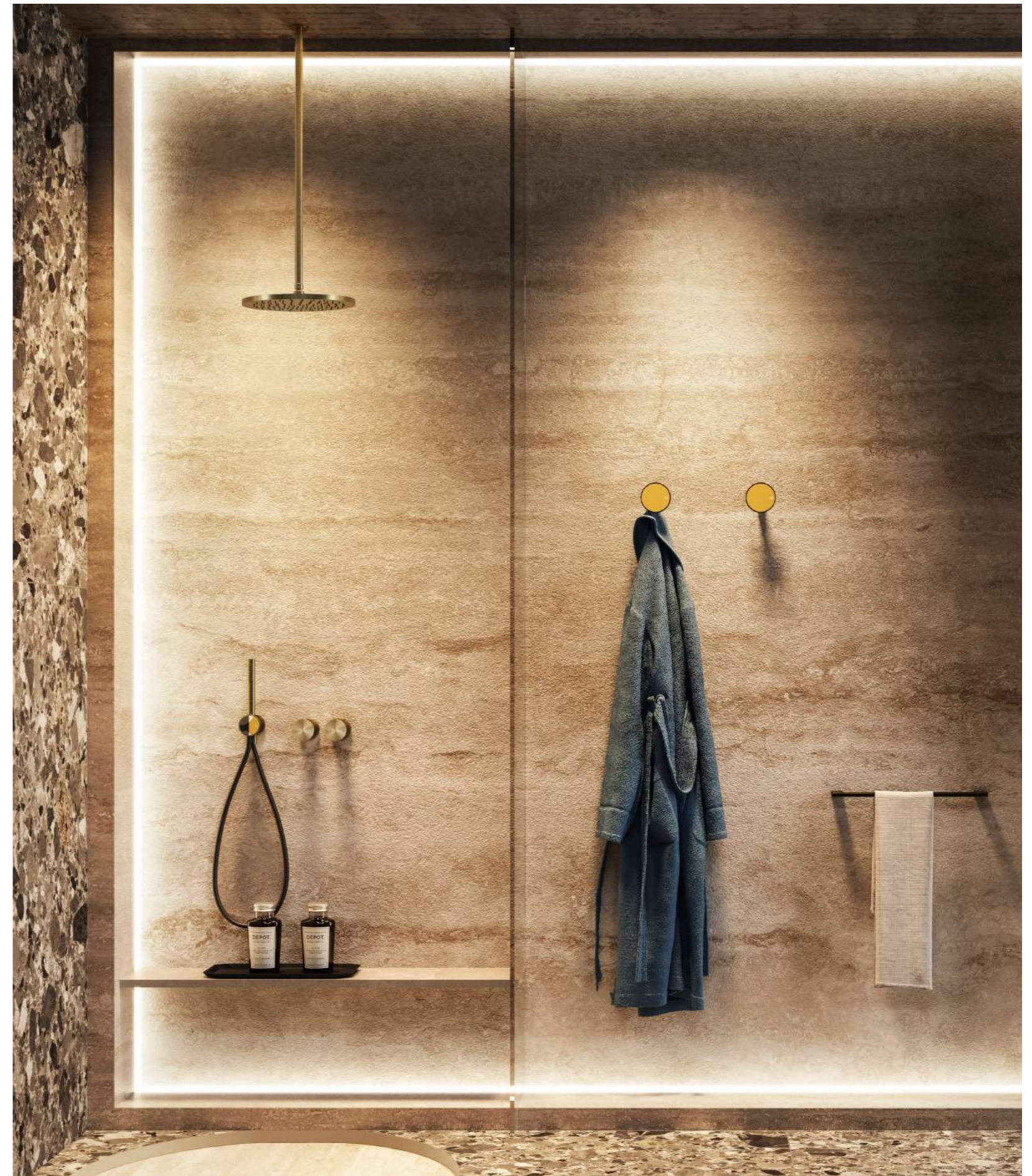

INSPIRATION IN THE CREATION OF ONE'S OWN PRIVATE WELLNESS

*Ispirazioni per creare il proprio
private wellness*

The original shape of the spout and enrichment of colour create a new language on the bathtub rim to provide the ultimate in expressive freedom. From inserts to accessories, matt black accents provide a sensation of visual depth.

L'originale forma dell'erogatore e l'arricchimento del colore portano un nuovo linguaggio a bordo vasca per offrire la massima libertà espressiva. Dagli inserti agli accessori, gli accenti nero opaco danno profondità visiva.



66037#727 + 66600#299 + 66602#277
Four-holes bath mixer + finish insert /
Gruppo bordo vasca quattro fori + inserti in finitura

727
BRASS BRUSHED PVD

299
MATTE BLACK

277
OCRA

OCRA

NCS S3040-Y10R

LAB 59,45/11,22/44,69

LCH 59,45/46,08/75,90

RGB 183/134/63

CMYK 0/27/66/28

ACCENT

Overview of the different potential combinations of Glossy Ochre, Brass Brushed and Matte Black finishes and their interchangeable decorative elements. The combination of numbers and letters simplifies the choice for designed products.

Overview delle diverse combinazioni possibili tra le finiture Ocra, Brass Brushed e Matte Black e i rispettivi inserti intercambiabili. L'abbinamento tra i numeri e le lettere semplifica la scelta per i prodotti disegnati.

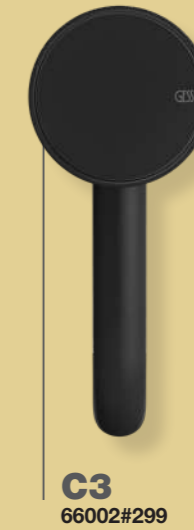
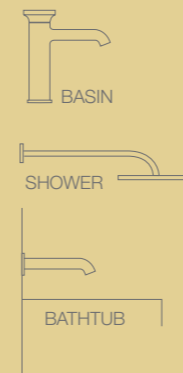
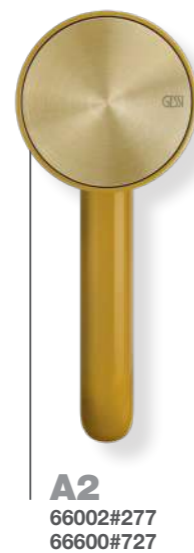
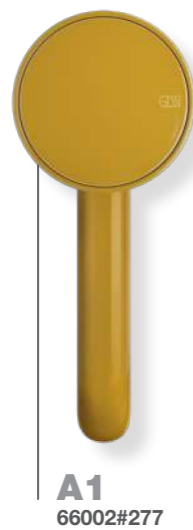
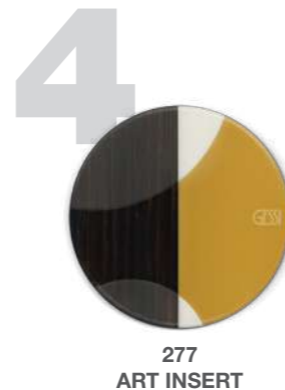

ORIGINI MATERIC

FOR TRADITION-LOVING, DOWN-TO-EARTH,
PEOPLE WHO DO NOT COUNT THE SECONDS

*Per amanti delle tradizioni, con i piedi per terra,
che vivono senza orologio.*

CORAL
BLACK METAL
COPPER

For tradition-loving, down-to-earth, people who do not count the seconds. The triad consisting of Coral, polished Black Metal and Brushed Copper establishes a multi-material ambience. It takes one back to the past to create a space where relaxation is the order of the day and tension can be released. It fits into any room where other materials such as wood, ceramics and resin cohabit to create a harmonious atmosphere. For those who live in a city studio flat but dream of a country cottage. This is a chromatic portrait of those who love peace and quiet.

Per amanti delle tradizioni, con i piedi per terra, che vivono senza orologio. La triade che comprende Coral, Black Metal lucido e Copper spazzolato definisce un ambiente polimaterico. Riporta al passato per dar vita ad uno spazio dove rilassarsi e scaricare le tensioni. Si inserisce in tutte le stanze in cui convivono altri materiali come il legno, la ceramica, la resina per creare un'armonia di luogo. Per chi vive in un monolocale di città sognando un casale di campagna. È il ritratto cromatico di chi ama la tranquillità.

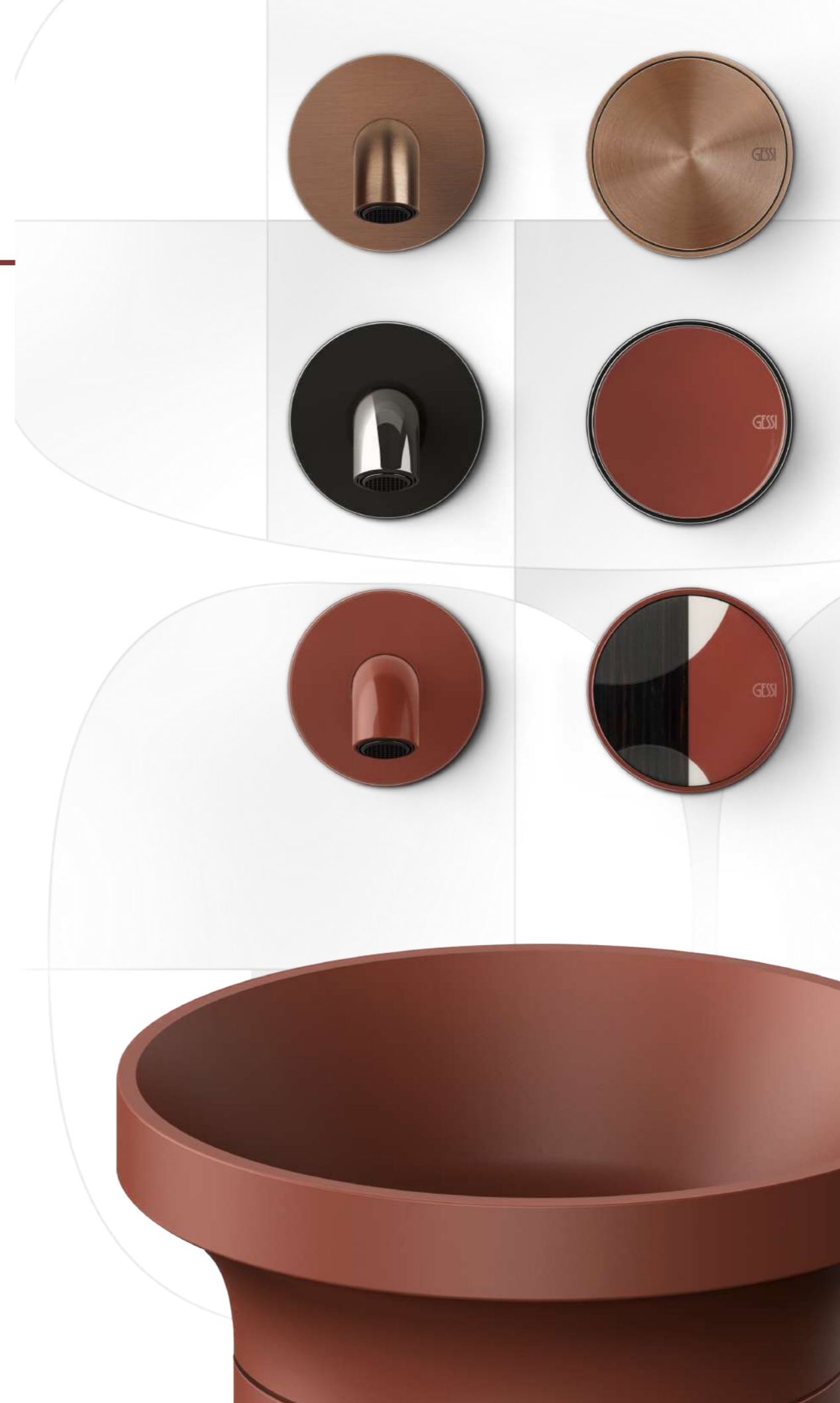

MATERIALITY

A contemporary rendition of origins, the MATERIC triad, in which the shapes are geometric and the materials traditional, is the one that most creates a bridge between past and future. Coral cotto and black metal in a polished version acquire an innovative identity and, alongside the predominantly lustrous copper, establish a dialogue with new monochromatic surfaces employed in architecture.

Interpretazione in chiave contemporanea delle origini, la triade MATERIC, in cui le forme sono geometriche e i materiali tradizionali, è quella che più crea un link tra passato e futuro. Il cotto Coral e il metallo nero proposti in versione lucida, acquisiscono un'identità innovativa e, insieme al rame, prevalentemente luminoso, dialogano con le nuove superfici monocromatiche impiegate in architettura.

REDISCOVER THE MEMORY OF TACTILE SENSATIONS

Riscoprire la memoria delle emozioni tattili

For a total bathroom look, the Cristalplant® washbasin with soft-touch effect picks up on the circular archetypal form of the ORIGINI collection set in a minimalist surrounding. Sturdy and modern, it is available for countertop or free-standing in all five finishes in addition to white and matt black.

Per un total look del bagno, il lavabo in Cristalplant® dall'effetto soft touch riprende la forma archetipa circolare della collezione ORIGINI in un contesto minimal. Solido e moderno è proposto da appoggio e free standing a stelo in tutte le cinque finiture oltre al bianco e al nero matt.



54198_66088#278 + 66602#278

54198_66088#706 + 66600#278

54198_66088#708

Wall-mounted basin mixer with spout, without waste + finish insert / Miscelatore lavabo a parete con bocca, senza scarico + inserto in finitura

66603#510

Cristalplant® freestanding washbasins, without overflow waste / Lavabo da terra in Cristalplant®, senza scarico troppopieno

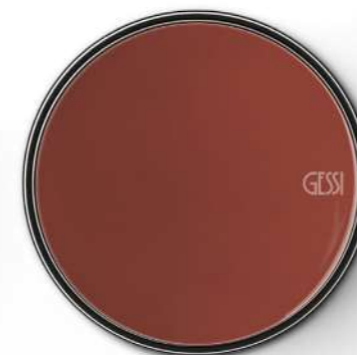

INTERCHANGEABLE INSERTS INFUSE TOUCHES OF LIGHT

Inserti intercambiabili infondono tocchi di luce



Thanks to the craftsmanship of the workmanship, the interchangeable inserts enhance the tactility of the metals. The lack insert, in particular, settles on the different elements and creates a visual rhythm that energises the spaces.

Grazie all'artigianalità delle lavorazioni, gli inserti intercambiabili esaltano la tattilità dei metalli. L'inserto nero, in particolare, posandosi sui diversi elementi crea un ritmo visivo che dinamizza gli spazi.



TO FIND ONE'S OWN INNER PEACE

Per ritrovare la propria pace interiore

Solid material surfaces in spaces featuring iconic materials such as wood, terracotta and ceramics, as well as reflective materials such as water, help create timeless moods where tactile pleasure translates into emotional comfort.

Trasmettono solidità le superfici materiche negli spazi caratterizzati da materiali iconici come legno, terracotta e ceramica, ma anche specchianti come l'acqua, contribuendo a creare atmosfere atemporali in cui il piacere tattile si traduce in comfort emozionale.

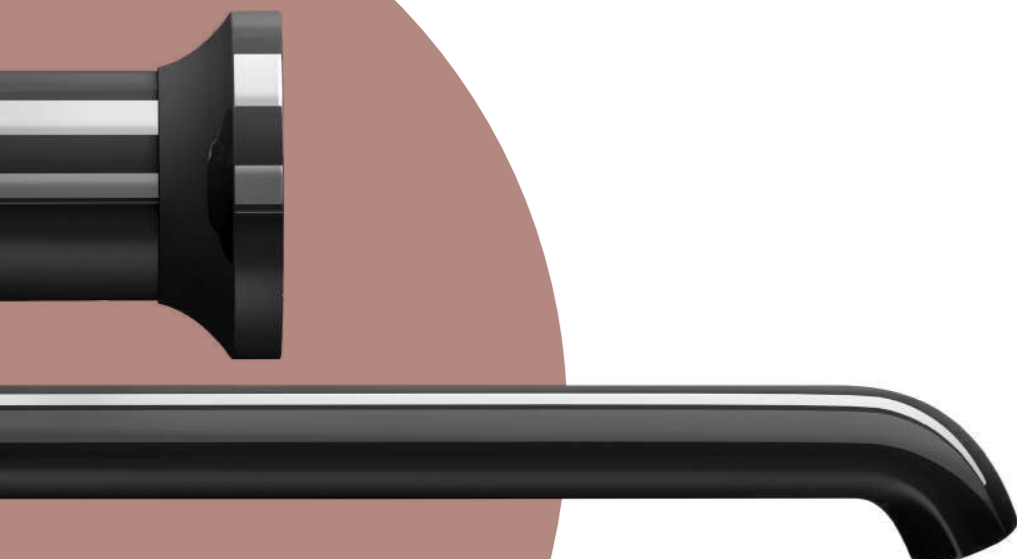

54198_66088#708 + 66600#278
54198_66088#706 + 66600#708
54198_66088#706

Wall-mounted basin mixer with spout, without waste + finish insert / Miscelatore lavabo a parete con bocca, senza scarico + inserto in finitura





66150#708

Wall-mounted adjustable showerhead / Soffione a parete orientabile

63013_66224#708 + 66600#278

Thermostatic mixer for three simultaneous functions, with push-button on/off controls + finish insert / Miscelatore termostatico a tre funzioni simultanee, con pulsanti on/off + inserto in finitura

65295#706

Waterfall shower spout / Bocca doccia a cascata

66142#706 + 66600#278

Sliding rail with hose and water outlet + finish insert / Asta saliscendi con presa acqua + inserto in finitura



FRESHNESS ARISING FROM DESIGN INNOVATION

La freschezza che nasce dall'innovazione nel design

A graphic interplay is created in the shower by the innovative round shower head that winds around the ceiling trim and by the slender tubular design of the sliding rail set where the line and the customisable element interact.

Un gioco grafico viene creato nella doccia dall'innovativo soffione rotondo che si snoda sul rosone e dalla sottile tubolarità dell'asta saliscendi in cui interagiscono la linea e l'inserto personalizzabile.

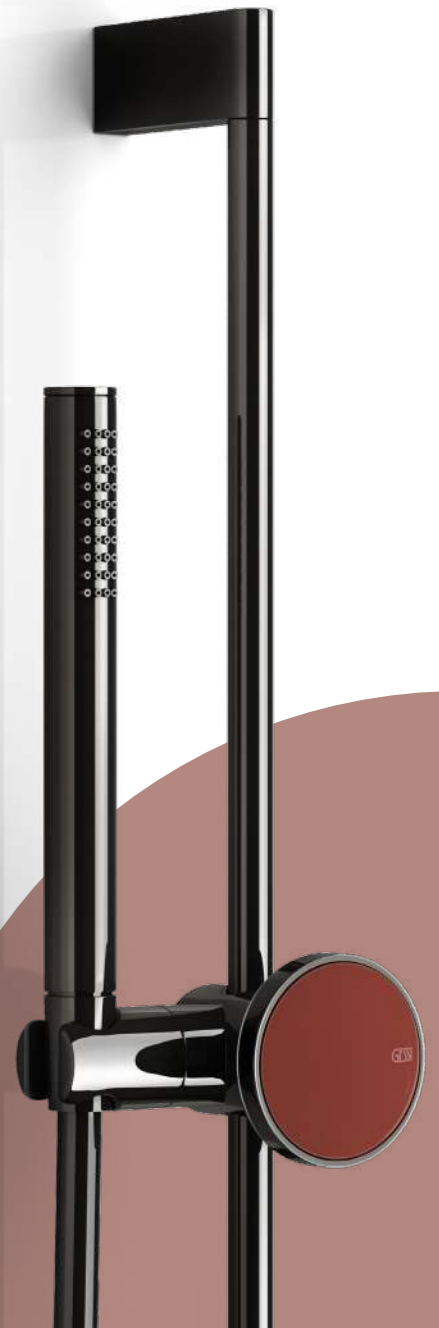
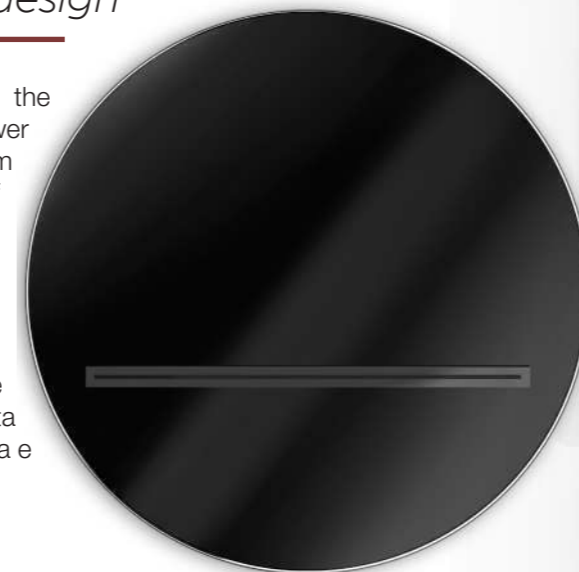



WHEN ACCESSORIES CONFER PERSONALITY TO A SPACE

Quando sono gli accessori a conferire personalità allo spazio

The high degree of modularity of the elements that constitute the collection balances the visual impact. The formal lightweight nature of the sliding rail set and tubular accessories, and the clear lines paired with pure circular elements, bestow personality onto the space.

L'alta modularità degli elementi che compongono la collezione calibra il risultato visivo. La leggerezza formale dell'asta saliscendi e dei tubolari degli accessori e le linee nette abbinata ad elementi circolari puri, conferiscono personalità allo spazio.

708
COPPER BRUSHED PVD

706
BLACK METAL PVD

278
CORAL

CORAL

NCS S5030-Y90R

LAB 33,12/24,49 / 14,19

LCH 33,12/28,30/30,08

RGB 119/61/57

CMYK 0/48/52/53



54139_66042#706 + 66600#278

Wall-mounted bath mixer, two-way + finish inserts /
Miscelatore vasca a parete, due vie + inserti in finitura

66123#706 + 66600#278

Shower set + finish insert /
Set doccia + inserto in finitura

66521#708 + 66602#278

Wall-mounted robe hook + ART insert /
Appendino a parete + inserto ART

66402

Black wall-mounted soap holder /
Porta sapone a parete nero

MATERIC

The result is that each moment spent in the most intimate of living spaces brings joy by the free combination of different elements to create environments in one's own image.

Il risultato che scaturisce dalla possibilità di abbinare tra loro liberamente i diversi elementi, per creare ambienti a propria immagine, dona gioia ad ogni momento trascorso nel luogo più intimo dell'abitare.

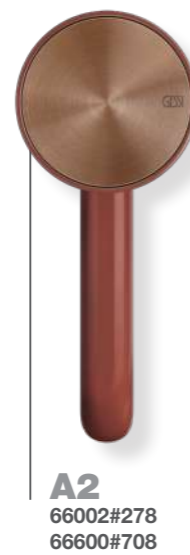
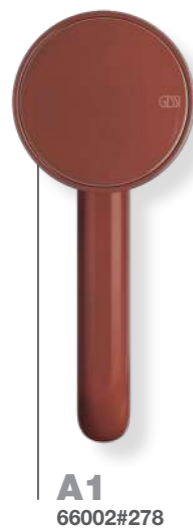
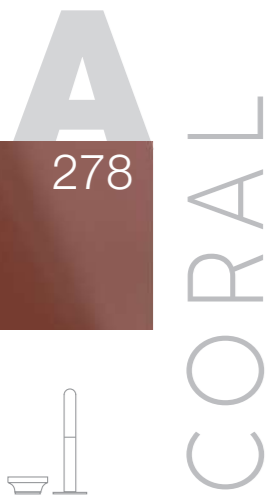

B
708

COPPER
BRUSHED PVD

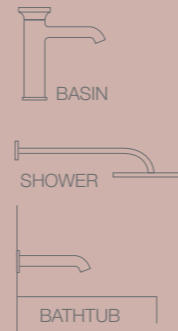
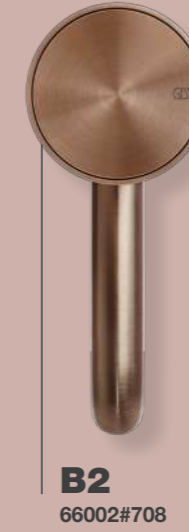

C
706

BLACK
METAL PVD

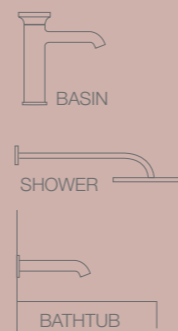

ORIGINI NATURE

FOR BIOMANIACS, UTOPIAN INTELLECTUALS AND
NATURE LOVERS FROM ALL OVER THE WORLD.

*Per biomaniaci, intellettuali utopici e
amanti della natura di tutto il mondo.*

AGAVE
BLACK
METAL
CHRO
ME

For biomaniacs, utopian intellectuals and nature lovers from all over the world. Brushed Black Metal, Chrome and Matt Agave green determine the triad of the metamaterial profile.

Green takes on the symbolic meaning of opening up horizons and moving the bathroom to the outside. NATURE brings nature into the home and complements all woods and plants. Poets and ecologists can thus freely experience the most minimal of spaces, close their eyes and listen to the soothing sound of water. This is a chromatic portrait of those who regenerate when in contact with nature.

Per biomaniaci, intellettuali utopici e amanti della natura di tutto il mondo. Black Metal spazzolato, Chrome e Agave opaco definiscono la triade del profilo metamaterico.

Il verde assume un significato simbolico per aprire gli orizzonti e spostare il bagno all'esterno. NATURE porta la natura in casa e si abbina a tutte le essenze e alle piante. Poeti e ecologisti possono così vivere liberamente gli spazi più minimal, chiudere gli occhi e ascoltare il rumore rilassante dell'acqua. È il ritratto cromatico di chi si rigenera a contatto con la natura.

NATURALNESS

Suitable for timeless atmospheres, the NATURE triad is metamaterial, since the green that represents it is not only a colour but also the philosophy for those who cherish nature and wish to live sustainably. Agave green in chlorophyll tones alongside the two neutral brushed black and chrome metals create a triad that is highly adaptable. It is recommended that it be combined with natural materials from all over the world such as rattan and teak, as well as with new generation sustainable materials. Full compatibility with all plants, from bamboo to ferns, goes without saying.

Adatta ad atmosfere senza tempo, la triade NATURE è metamaterica, perché il verde che la rappresenta non è solo un colore ma anche la filosofia di chi rispetta la natura e vuole vivere in modo sostenibile. Il verde agave nei toni clorofilla insieme ai due metalli neutri brushed black e chrome, crea una triade con una forte adattabilità. Si suggerisce di abbinarla sia con i materiali naturali provenienti da ogni parte del mondo come il rattan e il teak sia quelli sostenibili di nuova generazione. È intesa la massima compatibilità con tutte le piante, dal bambù alle felci.

FROM ON HIGH LIKE RAIN OR FROM BELOW LIKE A SPRING

Dall'alto come pioggia o dal basso come sorgente

A full recall to nature in a floor-standing mixer that evokes the primary origins of water, ideal for placement with a free-standing washbasin in the centre of a room. The wall-mounted round decorative element combined with the ceiling tube conveys the simplicity of a point and a line on a surface.

Massimo richiamo alla natura nel miscelatore da terra che ricorda le origini primarie dell'acqua, ideale per essere collocato con il lavabo free standing al centro di una stanza. Il comando da parete accostato al tubolare da soffitto esprime la semplicità del punto e della linea su una superficie.



FREE FLOW



GREEN, BLACK, CHROME OR PATTERNED ROUND DECORATIVE ELEMENTS

Inserti tondi verdi, neri, chrome o ART

46189_66095#031 + 66600#276
Freesranding basin mixer + finish insert /
Miscelatore lavabo da terra + inserto in finitura

66603#508
Cristalplant® freestanding washbasins,
without overflow waste /
Lavabo da terra in Cristalplant®,
senza scarico troppopieno

63399#276
Ceiling-mounted spout /
Bocca Lavabo a soffitto

54055_66109#276 + 66600#707
Wall-mounted basin/shower separate
control one-way + finish insert /
Comando remoto lavabo/doccia a parete,
una via + inserto in finitura

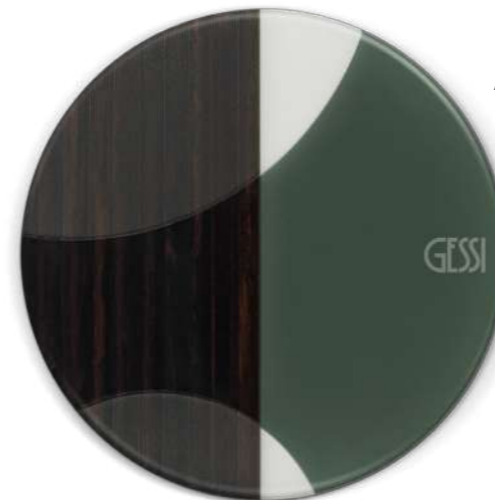

A circular element that leaves its mark with an abstract, modern graphic design. Four points that are able to coexist in the same environment for insertion with no rules, as nature intended.

Un elemento circolare che lascia il segno con la sua grafica astratta e moderna. Quattro punti che possono convivere nello stesso ambiente per inserimenti senza regole come in natura.







46189_66095#276 + 66600#707
Freestanding basin mixer + finish insert /
Miscelatore lavabo da terra + inserto in finitura

66603#508
Cristalplant® freestanding
washbasins, without overflow waste /
Lavabo da terra in Cristalplant®,
senza scarico troppopieno

63399#707
Ceiling-mounted spout / Bocca Lavabo a soffitto

54055_66109#707 + 66600#276
Wall-mounted basin/shower separate
control one-way + finish insert / Comando remoto lavabo/
doccia a parete, una via + inserto in finitura

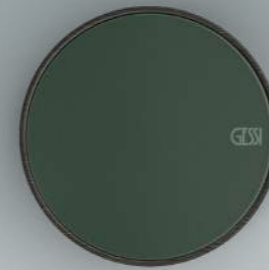

TO BROADEN VISUAL HORIZONS

Per allargare gli orizzonti visivi

Green dominates in the minds of those who live in harmony with nature, who appreciate the silence and beneficial effects of water. It moves with a free spirit in an environment it helped create, with no doors or barriers, such that nature is allowed to enter.

Predomina il verde nella mente di chi vive in sintonia con la natura, di cui apprezza il silenzio e i benefici effetti dell'acqua. Si muove con un'attitudine libera in un ambiente che ha contribuito a creare, senza porte né barriere, perché la natura potesse entrare.





57269#707
Wall-mounted adjustable showerhead - three settings /
Soffione doccia a parete orientabile, tre getti

54139_66036#707 + 66600#276 + 66602#276
Wall-mounted shower mixer, two-way + finish inserts /
Miscelatore doccia a parete, due vie + inserti in finitura



NEW LANGUAGE EXTRACTS FORM FROM COLOUR

*Nuovi linguaggi prendono
forma dal colore*

Each cornerstone of the collection brings an entirely fresh, original design solution, such as the innovative elimination of the trim for the support knobs. The mark of the round decorative element and the accent of the colour provide the ultimate in expressive freedom.

Ogni elemento cardine della collezione introduce una soluzione di design assolutamente fresca e originale come l'innovativa eliminazione del rosone per le manopole d'appoggio. Il segno circolare e l'accento del colore offrono massima libertà espressiva.

VISIBLE OR INVISIBLE SIGNS DEPENDING ON THE POINT OF VIEW

*Segni visibili e invisibili a seconda
del punto di vista*

Architectural renderings that enhance the minimal elegance of living spaces can be found in the ORIGINI accessories which graphically design walls using a sequence of circular and linear elements.

Le interpretazioni architettoniche che contribuiscono all'eleganza minimale degli spazi abitativi, si ritrovano negli accessori ORIGINI che disegnano graficamente le pareti con una sequenza di elementi circolari e lineari.

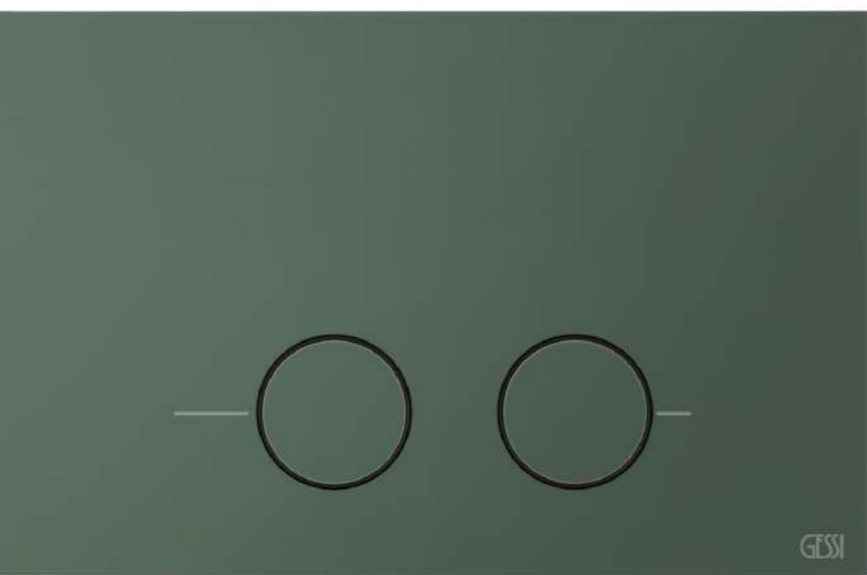

707
BLACK METAL BRUSHED PVD

031
CHROME

276
AGAVE

AGAVE

NCS S6010-B90G

LAB 41.10/-9.26/3.77

LCH 41.10/10.00/157.82

RGB 83/101/90

CMYK 18/0/11/60

58525#707

White Standing soap holder /
Porta sapone da appoggio bianco

66437#707

White Standing soap dispenser holder /
Porta dispenser da appoggio bianco

58531#707

White Standing tumbler holder /
Porta bicchiere da appoggio bianco

66007#276 + 66600#707

Bidet mixer + finish insert /
Miscelatore Bidet + inserto in finitura

NATURE

The harmonious union between the metals, the Black Metal Brushed PVD and Chrome finishes and Agave, the green colour in its most natural tone, bear witness to the high standard of design and the extreme depth of range in the ORIGINI collection.

La combinazione armonica tra i metalli, le finiture Black Metal Brushed PVD e Chrome e l'Agave, il colore verde nel suo tono più naturale, testimonia l'alto livello di progettazione e l'estrema profondità di gamma della collezione ORIGINI.



A 276 AGAVE



B 707

BLACK METAL BRUSHED PVD

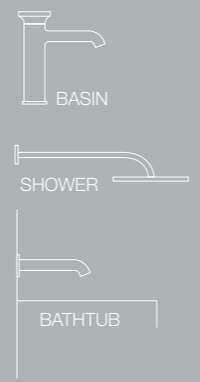

C 031

CHROME

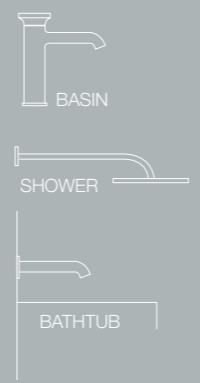

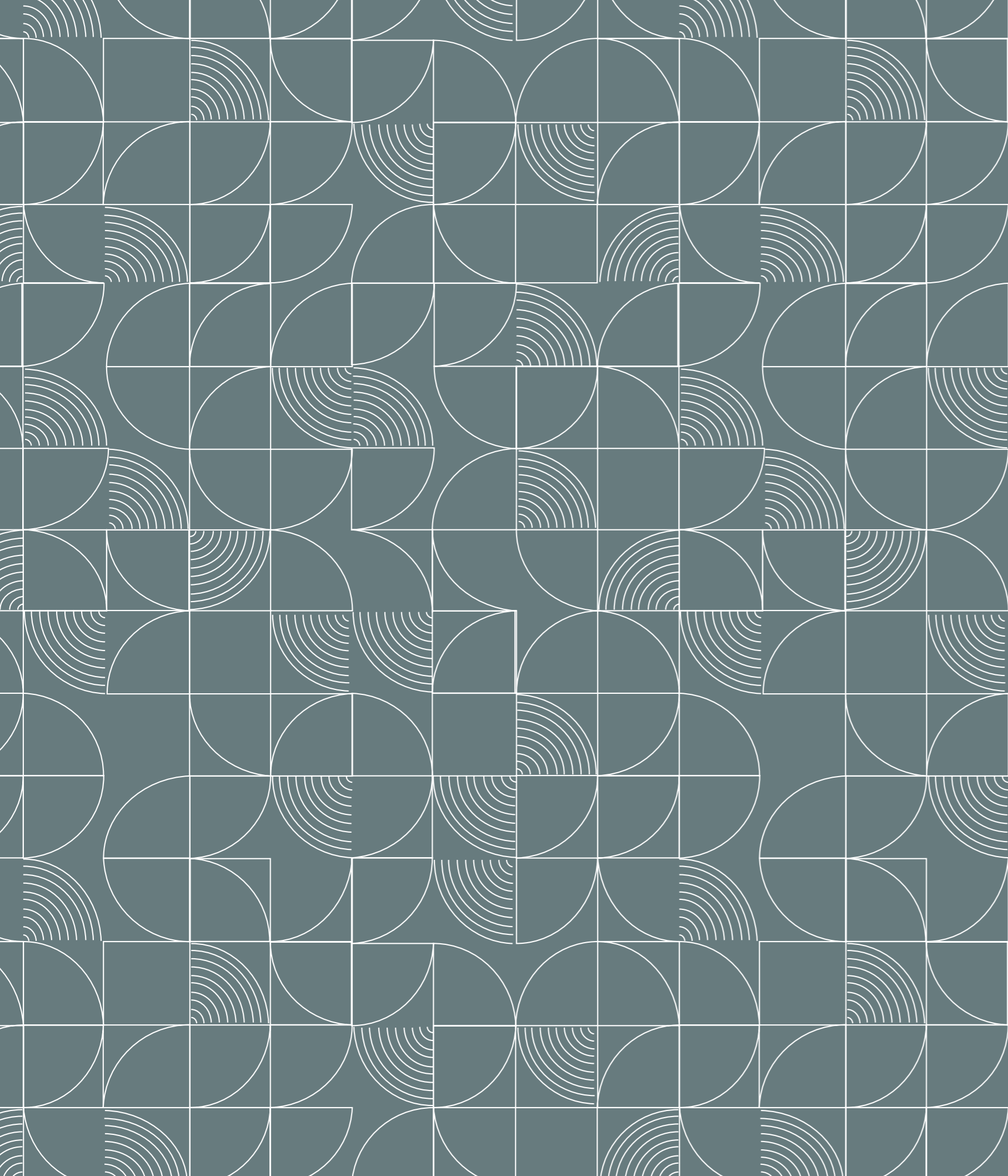

PRODUCT LIST

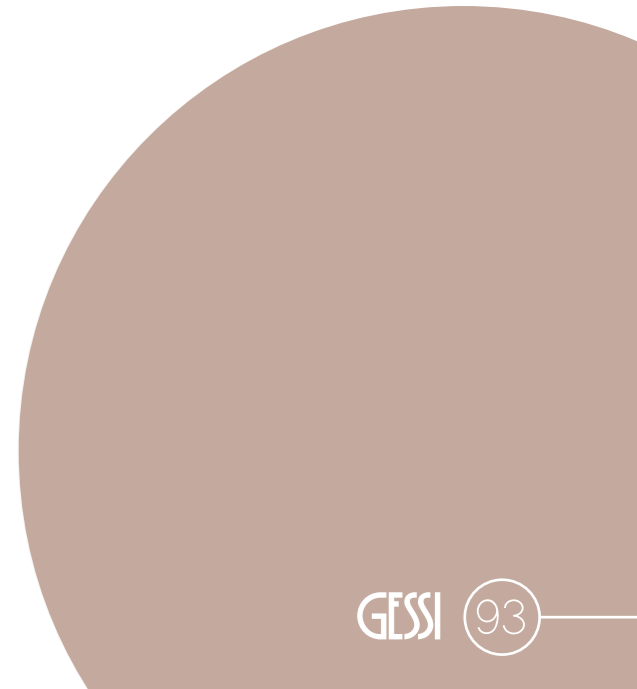



washbasin sanitary

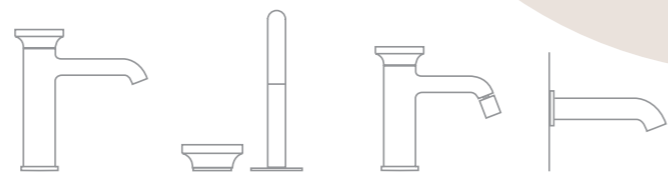

FLUSH PLATES
ONLY IN
MATT FINISHES:
#280 MATT OCRA
#281 MATT CORAL

INSERTI INTERCAMBIABILI INTERCHANGEABLE INSERTS

66600
Insert / Inserto



66600
Insert / Inserto



66600
Insert / Inserto



66602
ART insert / Inserto ART

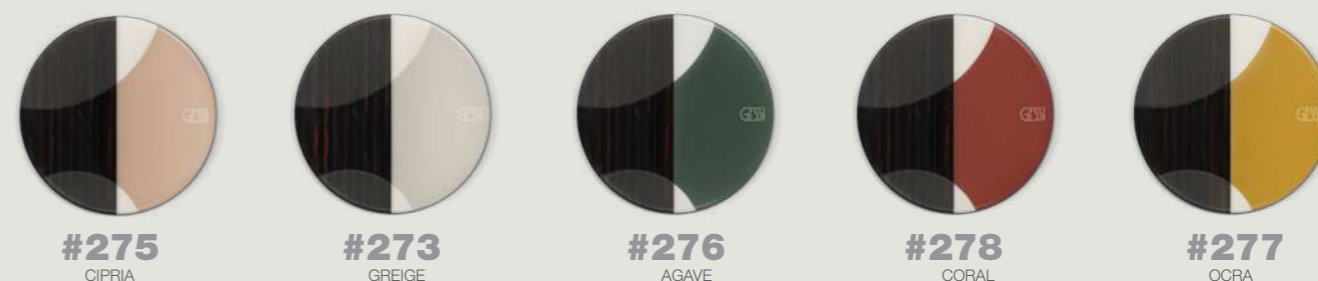

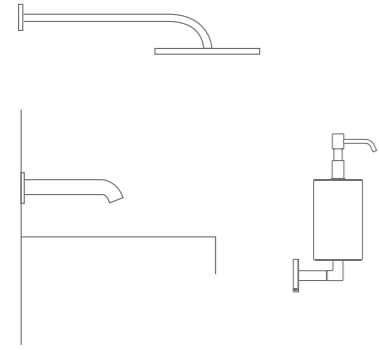

shower bathtub accessories

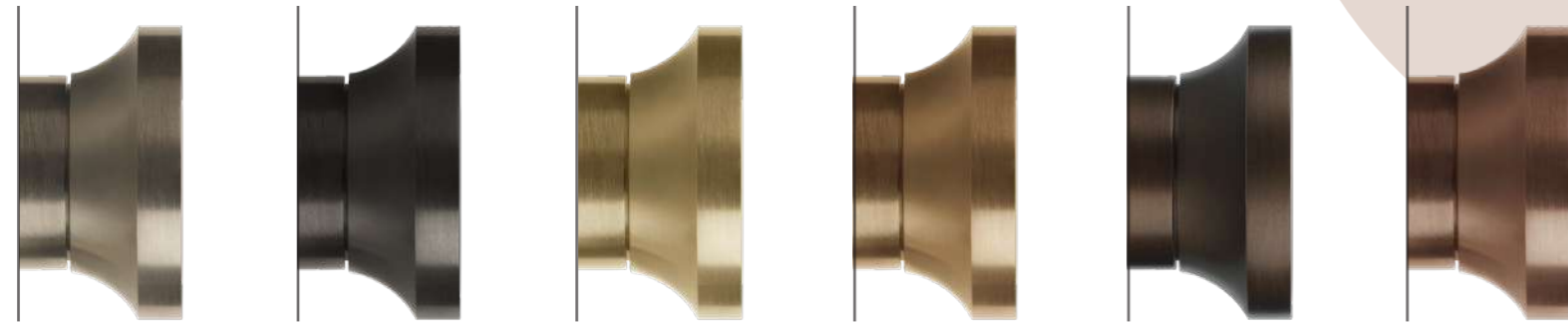

#149 FINOX
#707 BLACK METAL BRUSHED PVD
#727 BRASS BRUSHED PVD
#726 WARM BRONZE BRUSHED PVD
#845 DARK BRONZE
#708 COPPER BRUSHED PVD



#720 NICKEL PVD
#706 BLACK METAL PVD
#031 CHROME



#299 MATTE BLACK

INSERTI INTERCAMBIABILI INTERCHANGEABLE INSERTS

66600
Insert / Inserto



#149 FINOX
#707 BLACK METAL B. PVD
#727 BRASS B. PVD
#726 WARM BRONZE B. PVD
#845 DARK BRONZE
#708 COPPER BRUSHED PVD



#031 CHROME
#720 NICKEL PVD
#706 BLACK METAL PVD

66600
Insert / Inserto



#299 MATTE BLACK

66600
Insert / Inserto

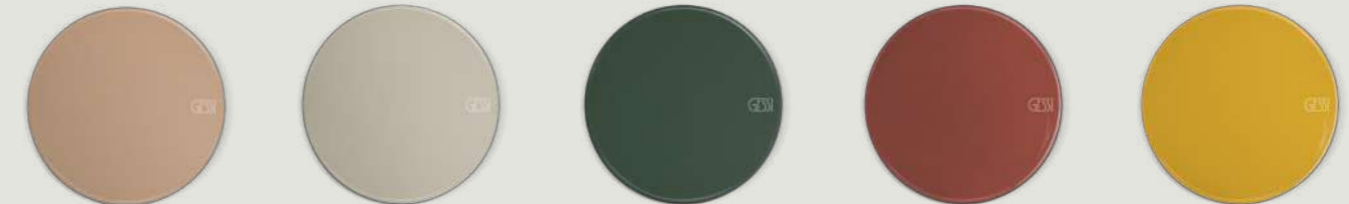

#275 CIPRIA
#273 GREIGE
#276 AGAVE
#278 CORAL
#277 OCRA

66602
ART insert / Inserto ART

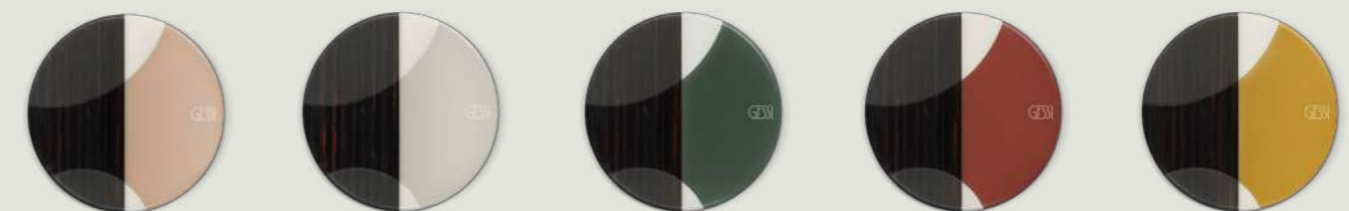

#275 CIPRIA
#273 GREIGE
#276 AGAVE
#278 CORAL
#277 OCRA

basin mixers

MISCELATORI PER LAVABO



66002
Basin mixer, without waste /
Miscelatore lavabo senza scarico
66001
With waste / con scarico



66006
Medium version basin mixer without
waste / Miscelatore lavabo medio
senza scarico
66005
With waste / con scarico



66004
Tall version basin mixer without
waste / Miscelatore lavabo alto
senza scarico
66003
With waste / con scarico



66014
Three-hole basin mixer, without
waste / Gruppo lavabo 3 fori medio
senza scarico
66013
With waste / con scarico



66016
Tall version three-hole basin mixer
without waste / Gruppo lavabo
3 fori alto senza scarico
66015
With waste / con scarico



66021
Medium spout basin /
Bocca Lavabo medio
66025
Tall version / Lavabo alto



66100
Separate control / Comando remoto



63399
Ceiling-mounted spout / Bocca
Lavabo a soffitto
63499
Length on request / Lunghezza
personalizzata



20699_66095
Freestanding basin mixer / Miscela-
tore lavabo a pavimento



54198_66088
Wall-mounted basin mixer with
spout, without waste / Miscelatore
Lavabo a parete con bocca senza
scarico



54055_66109
Wall-mounted basin/shower sepa-
rate control, one-way / Comando
remoto lavabo/doccia a parete 1 via



66102
Wall-mounted spout basin / Bocca
Lavabo a parete



30653
Electronic separate control /
Comando remoto Elettronico



66007
Bidet mixer / Miscelatore Bidet



44679_30564
Ceiling-mounted Electronic mixer /
Rubinetto Elettronico da soffitto
44679_30656
Length on request / Lunghezza
personalizzata



44679_30651
Built-in electronic separate control
/ Comando remoto Elettronico a
parete

bath & shower

VASCA E DOCCIA



66037
Four-holes bath mixer / Gruppo bordo vasca 4 fori
66043
Three-holes / tre fori



54139_66042
Wall-mounted bath mixer, two-way / Miscelatore vasca a parete 2 vie



54139_66036
Wall-mounted shower mixer, two-way / Miscelatore Doccia a parete 2 vie



66123
Shower set / Set doccia



63329
Shower set / Set doccia



46189_66028
Freestanding bath mixer / Miscelatore Vasca da terra



66103
Wall-fixing bath spout / Bocca vasca a parete



54073_66079
Wall-mounted shower mixer, two-way diverter / Miscelatore Doccia a parete 2 vie
54055_66109
One-way / una via



54169_66132
Thermostatic mixer, one-way / Miscelatore Termostatico Doccia a parete 1 via
54169_66134
Two-way / due vie
54169_66136
Three-way / tre vie



66238_66138
Thermostatic built-in mixer / Miscelatore incasso termostatico



66240_66140
Stop valve for thermostatic mixer / Rubinetto d'arresto per miscelatore termostatico



66150
Wall-mounted adjustable showerhead / Soffione a parete orientabile



66148
Wall-mounted adjustable showerhead / Soffione a parete orientabile



63352
Ceiling-mounted adjustable showerhead / Soffione a soffitto orientabile
63350
Length on request / Lunghezza personalizzata



57269
Wall-mounted adjustable showerhead - three settings / Soffione a parete orientabile, tre getti
57261 Multi-spray
57263 Rain
57265 Mist
57267 Waterfall



63011_66222
Thermostatic mixer for two simultaneous functions, with push-button on/off controls / Miscelatore termostatico a due funzioni simultanee, con pulsanti on/off



63013_66224
Thermostatic mixer for three simultaneous functions, with push-button on/off controls / Miscelatore termostatico a tre funzioni simultanee, con pulsanti on/off



63015_66226
Thermostatic mixer for four simultaneous functions, with push-button on/off controls / Miscelatore termostatico a quattro funzioni simultanee, con pulsanti on/off



66144
Sliding rail / Asta saliscendi



66142
Sliding rail with hose and water outlet / Asta saliscendi con presa acqua
66145
Without water outlet / senza presa acqua

private wellness



57603_57018

Rainfall ø350 mm
57601_57018 Built-in
57303_57002
 300 x 300 rainfall
57301_57002 Built-in
57307_57004 300 x 300 rainfall / waterfall
57305_57004 Built-in
57403_57006 300 x 500 rainfall
57401_57006 Built-in
57401_57010 300 x 500 rainfall / waterfall
57409_57010 Built-in
57503_57012 500 x 500 rainfall
57501_57012 Built-in
57016_57511 500 x 500 mist multifunction
57016_57509 Built-in



57829_57878

Multifunction ø350 mm
57929_57980 Multifunction ø500 mm
57827_57876 350 X 350 Multifunction
57831_57882 300 X 500 Multifunction
57927_57977 500 X 500 Multifunction



57803_57018

Rainfall ø350 mm
57809_57873 Multifunction
57903_57973 Rainfall ø500 mm
57909_57975 Multifunction ø500 mm
57801_57871 350 X 350 Rainfall
57807_57875 Multifunction
57805_57006 300 X 500 Rainfall
57811_57010 Multifunction
57901_57012 500 X 500 Rainfall
57807_57016 Multifunction



65295

Waterfall shower spout / Bocca doccia a cascata



32977

Lateral nebulizer / Nebulizzatore laterale



32985_32982

Adjustable lateral body jet / Soffione laterale orientabile



13375

Adjustable lateral body jet / Soffione laterale orientabile



32971

Lateral body jet / Soffione laterale



63215_63210

Two exit Shower Column. To be completed with lever kit and showerhead / Colonna Doccia da esterno due vie.

63215_63209 One exit / Una via

66212 Lever+Handshower kit for 63210 / Kit maniglia e doccia per 63210

66211 Lever kit for 63209/Kit maniglia per 63209

66152

Adjustable showerhead/Soffione orientabile

FINISHING

#239 Steel Brushed
 #299 Matt Black
 #856 Corten
 #275 Matt Cipria
 #273 Matt Greige
 #280 Matt Ocro
 #281 Matt Coral
 #276 Matt Agave

accessories

ACCESSORI



66401

White wall-mounted soap holder / Porta sapone a parete bianco

66402
 Black / nero

58525
 White standing / Da appoggio bianco

58526
 Black / nero



66407

Wall-mounted tumbler holder white / Porta bicchiere a parete bianco

66408
 Black / nero

58531
 White standing / Da appoggio bianco

58532
 Black / nero



66413

Wall-mounted soap dispenser holder white / Porta dispenser a parete bianco

66414
 Black / nero

66437
 White standing / Da appoggio bianco

66438
 Black / nero



66455

Paper-roll holder for horizontal/vertical installation / Porta rotolo a parete orizzontale o verticale



66521

Wall-mounted robe hook / Appendino a parete



66504

60 cm towel rail / Portasalvietta 60 cm

66500

30 cm

66502
 45 cm



66515

60 cm towel rail for glass fixing / Maniglia e portasalvietta per vetro 60 cm

66511
 30 cm

66513
 45 cm



66419

White wall-mounted brush holder / Porta scopino a parete bianco

66420
 Black / nero

58543
 White standing / Da appoggio bianco

58544
 Black / nero

total look



66603

Freestanding washbasin in Cristalplant®, without overflow waste / Lavabo da terra in Cristalplant®, senza scarico troppopieno

#521 CRISTALPLANT MATT WHITE
#511 CRISTALPLANT MATT BLACK
#507 CRISTALPLANT MATT CIPRIA
#506 CRISTALPLANT MATT GREIGE
#509 CRISTALPLANT MATT OCRA
#510 CRISTALPLANT MATT CORAL
#508 CRISTALPLANT MATT AGAVE



54611

Cover plate / Placca di finitura

54613

54615

54617

54619

54621

#031 CHROME

#239 STEEL BRUSHED

#299 MATT BLACK

#720 NICKEL PVD

#706 BLACK METAL PVD

#707 BLACK METAL BRUSHED PVD

#727 BRASS BRUSHED PVD

#726 WARM BRONZE BRUSHED PVD

#708 COPPER BRUSHED PVD

#845 DARK BRONZE

#275 MATT CIPRIA

#273 MATT GREIGE

#280 MATT OCRA

#281 MATT CORAL

#276 MATT AGAVE



66601

Counter washbasin in Cristalplant®, without overflow waste / Lavabo da appoggio in Cristalplant®, senza scarico troppopieno

#521 CRISTALPLANT MATT WHITE
#511 CRISTALPLANT MATT BLACK
#507 CRISTALPLANT MATT CIPRIA
#506 CRISTALPLANT MATT GREIGE
#509 CRISTALPLANT MATT OCRA
#510 CRISTALPLANT MATT CORAL
#508 CRISTALPLANT MATT AGAVE



39113

Wall hung WC (6 litres) in Ceramic, integrate siphon. Soft-closing hardware / Vaso in Ceramica a parete (6litri) con sifone integrato. Cerniere Soft-close incluse

#518 WHITE CERAMIC

#531 MATT WHITE CERAMIC

#532 MATT BLACK CERAMIC



39118

Wall hung WC (6 litres) in Ceramic, integrate siphon. Soft-closing hardware / Vaso in Ceramica a parete (6litri) con sifone integrato. Cerniere Soft-close incluse

#518 WHITE CERAMIC

#531 MATT WHITE CERAMIC

#532 MATT BLACK CERAMIC



39115

Wall hung Bidet in Ceramic, with overflow waste and hole for tap and fittings. / Bidet in Ceramica a parete con troppopieno e foro centrale per rubinetteria.

#518 WHITE CERAMIC

#531 MATT WHITE CERAMIC

#532 MATT BLACK CERAMIC

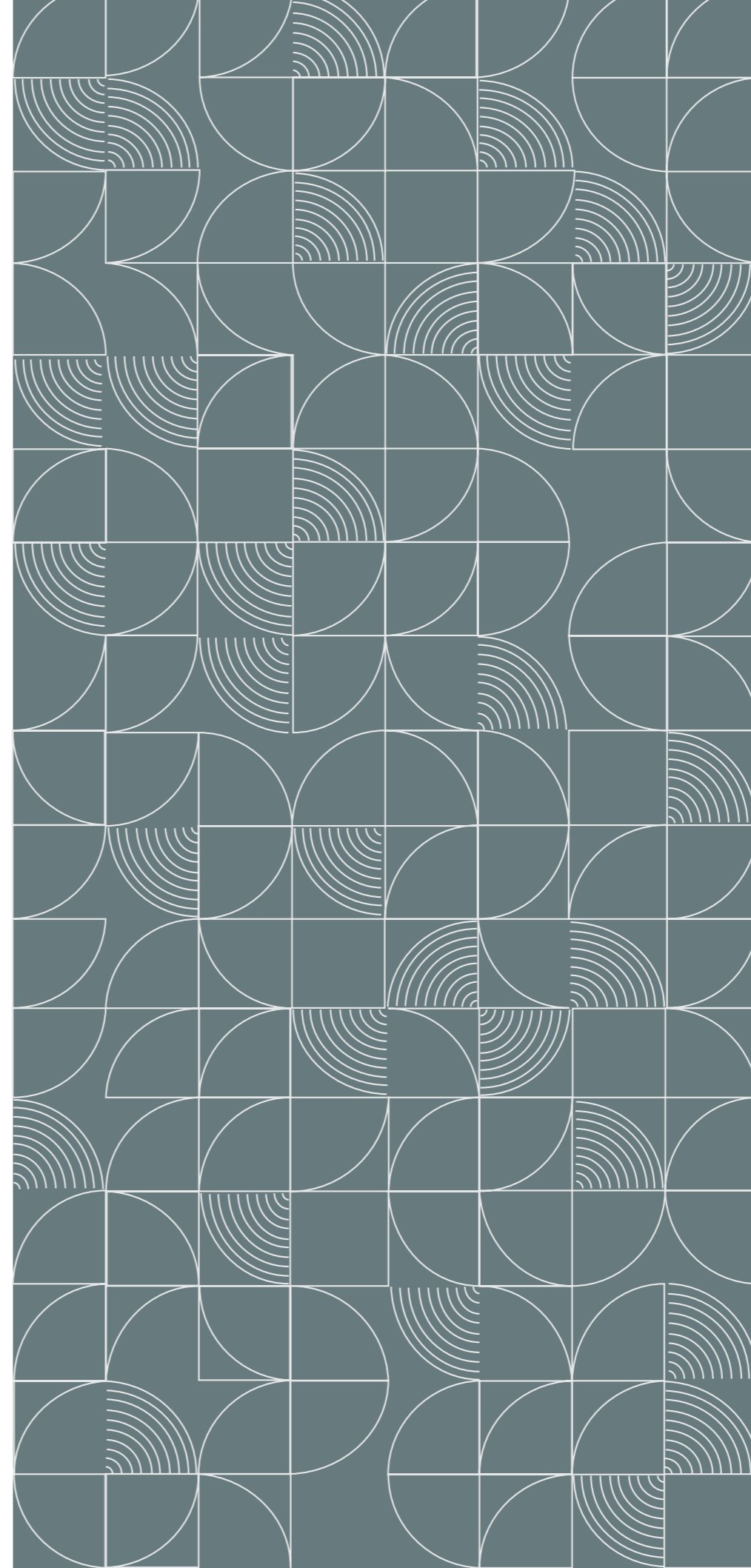

Le illustrazioni e le descrizioni contenute nel presente catalogo e negli stampati della venditrice non comportano obbligo di fedele esecuzione; i dettagli e le misure contenute sono da considerarsi indicativi e soggetti a modifiche senza preavviso. Eventuali errori e/o refusi di stampa del presente catalogo non costituiscono motivo di contestazione.

The images and descriptions included in our literature do not constitute an obligation of an accurate realization of the product, the details and the measurement included are to be used as a guide and maybe modified without notice. Possible mistakes and/or misprints of current catalogue will not be object of dispute.



www.gessi.com



Download Gessi APP

GESSI SpA 捷仕
Parco Gessi - 13037 Serravalle Sesia
(Vercelli) ITALY
Tel. +39 0163 454111
Fax +39 0163 459273
gessi@gessi.it

ED. JUNE 2022
GMC006210